

DeltaFx™ Fiberized Spray Applicator

DeltaFx™ fiberized spray applicators provide exceptional value and flexibility for wide adhesive lamination. Using the ITW Dynatec patented Laminate Plate Technology, DeltaFx™ provides an easy-to-use and maintain Non-Contact Application System. An excellent choice for a number of applications where speed, versatility and durability are required that works with all types of hot melt adhesives including PUR Hot Melts.

DeltaFx™ Fiberized Spray Applicator:

- Consistent coat weight application eliminates ridges and valleys common when using swirl applicators.
- Random fiber patterns use less adhesive than spiral spray and maintain or improve bond strength.
- Adhesive pattern widths can be easily adjusted by controlling the head height to the substrate.
- Minimizes clean-up and reduces downtime.

Performance

Continuous application of adhesives including: PSA, APAO, and Reactive Hot Melts.

Flexibility

Quick-change pattern width(s) by adjusting the distance between head position and the substrate.

Innovation

Single nozzle permits a range of pattern widths up to 12 inches. (adhesive dependent)

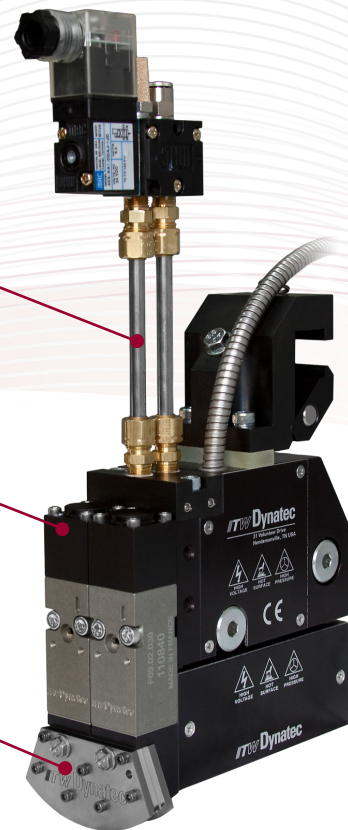

ITW Dynatec - DeltaFx™ Brand Fiberized Spray Applicators

The Dynatec Difference...

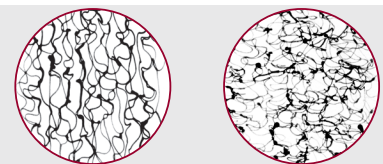

Actual Fiber Patterns Shown

Easy Pattern Adjustment and Simplification

DeltaFx™ applicators allow up to a 12" pattern width per head and can be easily changed to accommodate smaller widths by adjusting the distance between the applicator and the substrate itself. For applications requiring the use of reactive hot melt adhesives, DeltaFx™ has been designed with direct glue paths which eliminate blind and inactive adhesive

passages. By reducing the risk of cured adhesive, DeltaFx™ provides a long and trouble-free operating life. Easy to clean and easy to set up, DeltaFx™ is the answer for those looking to reduce down time, improve productivity and reduce floor space in their laminating station.

DeltaFx™ Fiberized Spray Applicator

System	DeltaFx™	Comments
Application Width per Nozzle	Up to 305 mm (12 in)	Varies depending upon distance to substrate.
Adhesive Viscosity	Lab Test Required	-
Temperature Range	40°C to 200°C (100°F to 400°F)	-
Warm-Up Time	15 min. (cold start)	-
Typical Application Air Pressure	0.8 - 1.5 bar (12-22 psi)	Depends upon type of adhesive.
Typical Air Flow per Nozzle	2,500 (nl/h) (1.5 SCFM)	-
Wattage Manifold	450W	-
Wattage Air Heater	600W	-

*Laboratory tests are required to verify pattern widths as adhesive viscosity and other variable effect application performance.

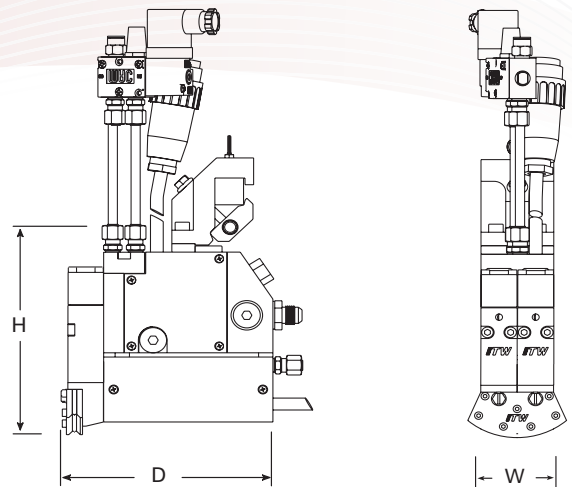
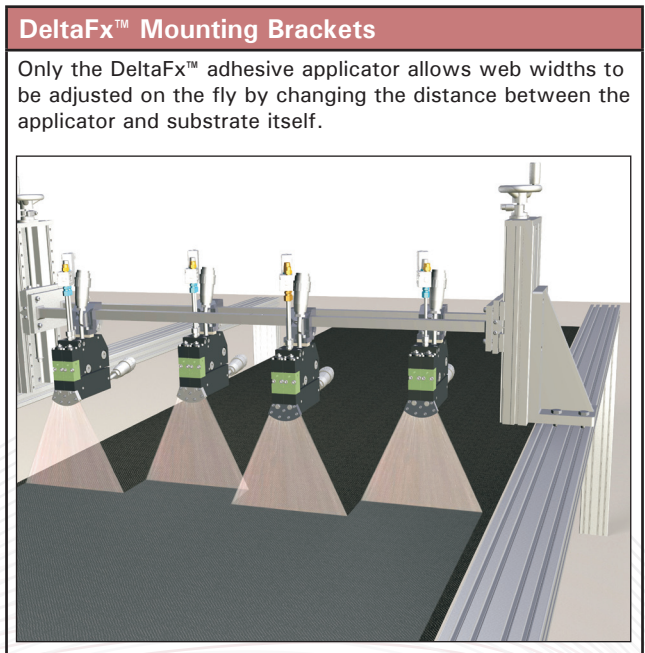
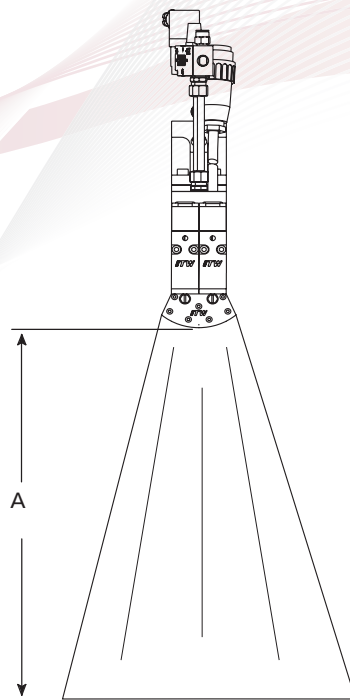

Dimensions	DeltaFx™
Height (H)	261 mm (10.28 in)
Depth (D)	146.3 mm (5.76 in)
Width (W)	50 mm (1.97 in)
Adjustment (A)	50 mm-200 mm (1.97 in to 7.8 in)



ASIA
ITW Dynatec Hong Kong
Unit A-B, 11/Fl., Leahander
Centre 28
Wang Wo Tsai Street
Tsuen Wan NT Hong Kong

AMERICAS
ITW Dynatec
31 Volunteer Drive
Hendersonville, TN 37075
Telephone 615-824-3634
+1.800.860.6150
Fax +1.615.264.5248
dynatec@itwdynatec.com

JAPAN
ITW Dynatec K.K.
Tsukimura Building 5th Floor
26-11, Nishikamata 7-chome
Ota-ku, Tokyo 144-0051, Japan
Telephone +81.3.5703.5501
Fax +81.3.5703.5505
info@itwdynatec.co.jp

EUROPE, AFRICA and MIDDLE EAST
ITW Dynatec GmbH
Industriestrasse 28
D-40822 Mettmann, Germany
Telephone +49.210.4915.0
Fax +49.210.491.5111
e.mail@itwdynatec.de

© 12/2010 ITW Dynatec
ITW Dynatec reserves the right to discontinue or change specifications, designs, materials and equipment without notice or obligation.

Visit us at www.itwdynatec.com